

1. GENERAL

The SPL-5020 outdoor siren is designed for application in burglary and panic alarm systems. The signaling function is performed in two ways: **optically** (by lamp blinking) and **acoustically** (with a modulated high-volume sound signal). The source of light is a 5W/12V incandescent lamp, while the sound signal is generated by means of a piezoelectric transducer. Electronic circuit of the siren is made in SMD technology and impregnated against adverse effect of weather conditions, which ensures a high reliability of the equipment. As the outer shell of the SPL-5020 is made of PC LEXAN high-impact polycarbonate, it features a very high mechanical strength and guarantees esthetic look of the equipment even after many years of service.

2. INSTALLATION

The SPL-5020 siren should be mounted on flat surface, at a place as much inaccessible as possible so that the risk of tampering is minimized. The siren must be attached to the surface by means of screws and expansion plugs. In order to take off the cover, remove the retaining screw and lift it by an angle of approx. 80°. Be particularly careful when dismantling and remounting the inner sheet metal cover.

Note: Make sure there is a suitable distance (minimum 2.5cm) between the upper edge of the siren base and the ceiling or another element restricting the mounting position from the above. Otherwise, replacement of the cover may be impossible.

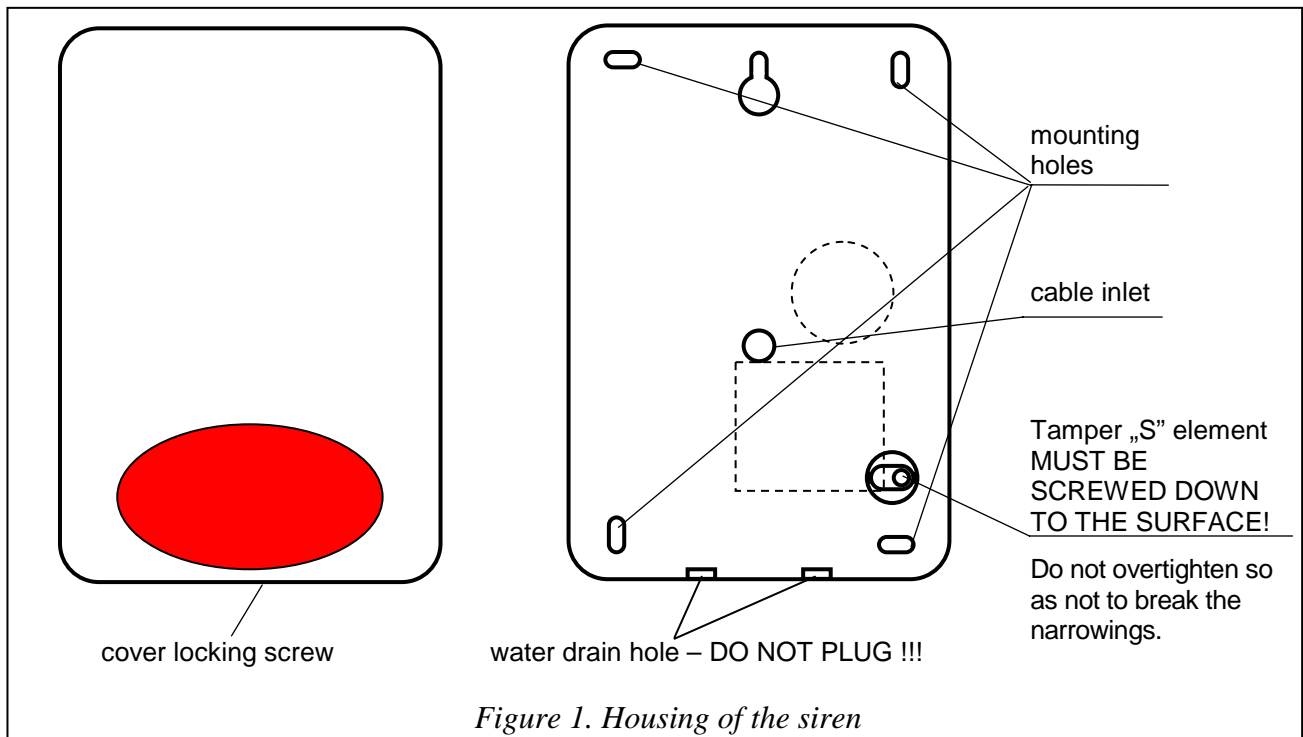

After installation of the siren, it is recommended that the mounting holes as well as the cable inlet be sealed by means of silicone compound.

3. CONNECTION

The SPL-5020 siren can be used with any source of alarm signal which in emergency situation generates 12V direct voltage on its alarm output(s) or whose output will be shorted to the common ground (0V). The acoustic signaling is controlled by the **SA** input, while the optical signaling – by the **SO** input. The kind of triggering signal is to be set with the JP1, JP2 jumpers.

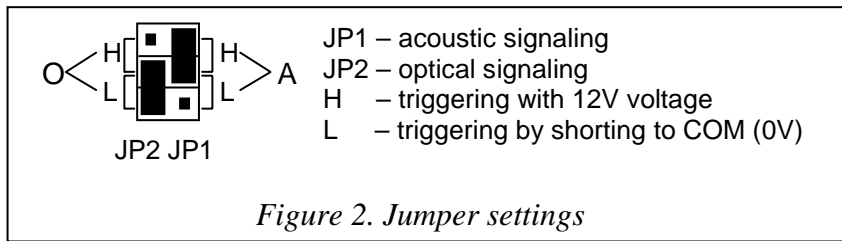

The siren is designed for work both with or without a 12V/0.8Ah battery installed (own power supply). Battery should be connected to the BATTERY connector on PCB. If there is a battery installed, the supply voltage should be within the range of **13V to 13.8V**, so that the proper charging process can be ensured. The siren supply voltage is to be connected to the terminals +12V and GND. Voltage loss across these terminals (with the siren battery connected) will set off the acoustic alarm for a period of maximum 6 minutes. An earlier restoration of supply will stop the alarm signaling. It should be borne in mind that the current output of the alarm control panel must be sufficient for correct operation of the device.

The tamper circuit of the siren reacts to removal of the outer shell as well as pulling the device off the wall. To make the functional test of the pull-off alarm possible, there must be the "S" element screwed down to the surface (Fig. 1).

The "TMP" terminals are used to connect the siren to the security system tamper circuit.

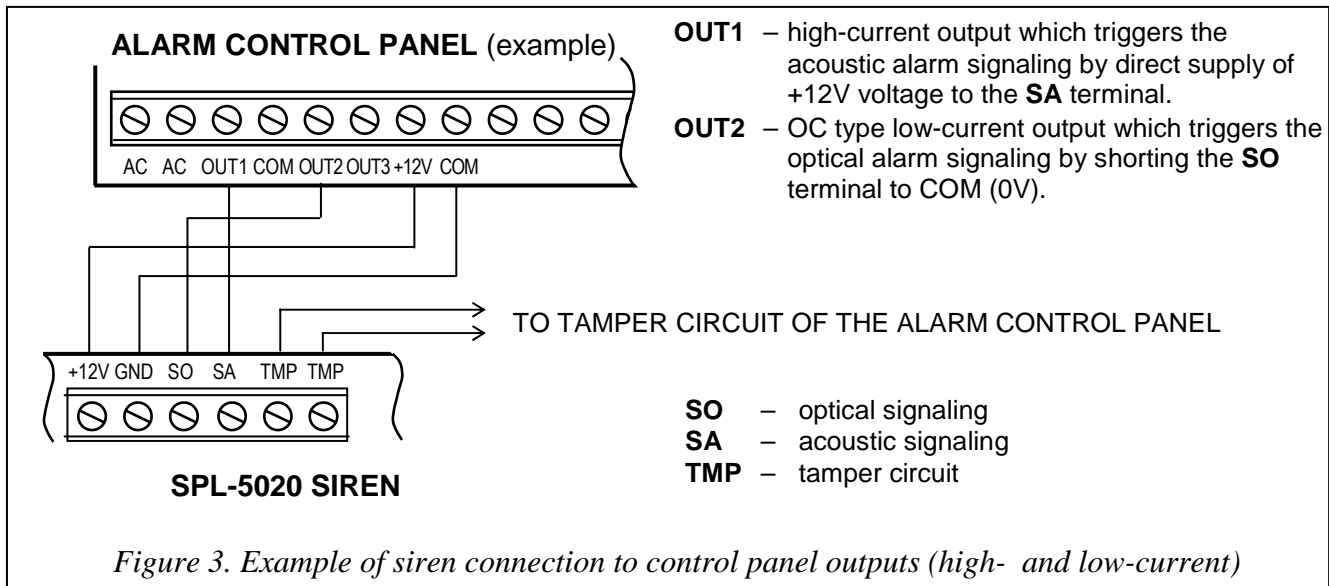

4. TECHNICAL DATA

Supply voltage, rated – siren without back-up battery.....	12V DC ±15%
Supply voltage – siren with back-up battery.....	13...13.8V DC
Current consumption – acoustic signaling	200mA
Average/max. current consumption – optical signaling	350mA/500mA
Back-up battery (recommended)	12V/0.8Ah
Battery charging current	approx. 100mA
Battery protection	fuse T 3.15A
Sound intensity.....	approx. 120dB
Working temperature.....	-35°C...+60°C
Dimensions	298x197x72mm
Weight.....	757g

SATEL sp. z o.o. ul. Schuberta 79 80-172 Gdańsk POLAND	tel. +48 58 320 94 00 info@satel.pl www.satel.pl	Latest EC declaration of conformity and product approval certificates can be downloaded from our Web site www.satel.pl 
---	--	---